

TouchFree Ultra™ Dispensers



Attractively designed, power efficient touch free dispensing system for use with DebMed foaming hand hygiene products.

WHERE TO USE

Suitable for use in healthcare facilities. May also be used for hallways, office and reception / lobby areas in conjunction with Alcare® Extra Foaming Hand Sanitizer and dispenser stand.

HOW TO USE

Simply hold hand under dispenser to activate. No touch required

DISPENSER

FEATURES	BENEFITS
Touch Free dispenser	• Encourages use and minimizes any risk of cross-contamination
Versatile	• Can be used on walls in washrooms, hospital corridors, patient rooms or on DebMed's free standing stand
Exceptionally Long Battery Life	• The power provided by 4 D-Cell batteries will provide up to 4 years of operation in typical healthcare usage conditions
Reliable	• Uses the latest infrared sensing technology for reliable operation to prevent misfiring
Large Capacity	• Cartridges contain 1.2 liter of foam handwash product providing approximately 1715 applications and 1 liter Alcare® Extra hand sanitizer providing 1430 applications
Lock and Keyless Option	• For maximum security the dispenser can be locked and opened with the special key provided • Alternatively it can be easily converted to a keyless, non-locking button operation
Color Options	• Available in a range of colors to match different environments
Customizable	• TouchFree Ultra dispensers are fully customizable and can be tailored to any environment

TECHNICAL SPECIFICATIONS

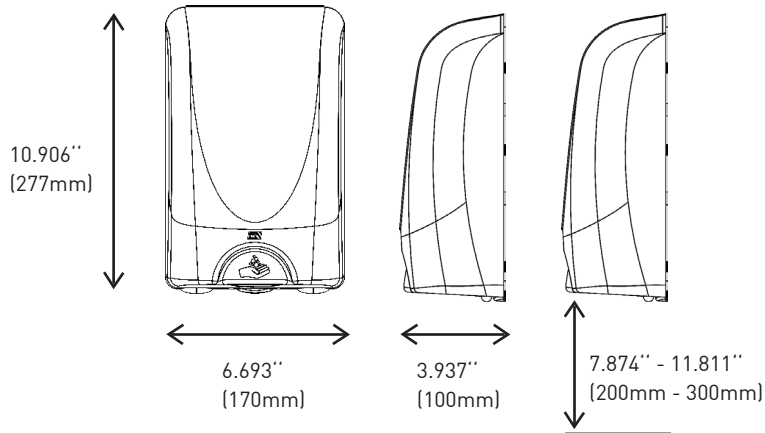

DIMENSIONS

- 6.693" wide x 3.937" deep x 10.906" high
- Gross weight: 6.4lb (complete with batteries and cartridge)
- Ensure unit is located with appropriate space to each side and below

- Requires the use of 4 high quality Alkaline D-Cell batteries to maximize units operating time
- Fully ADA compliant
- WEEE regulation compliant
- ROHS directive compliant
- DO clean with a damp cloth
- DO NOT hose down or spray with water
- DO NOT use abrasive cleaners
- DO NOT use solvent based cleaners
- DO NOT use caustic or acid based cleaners

LIFETIME GUARANTEE

Malfunctioning or broken dispensers through normal wear and tear while using DebMed products will either be repaired or replaced at no charge.

Code	Dispenser	Color	Case QTY	Cartridge capacity	For use with
155606	TouchFREE Ultra Sanitizer	white & purple	8	1/1.2 liter	1019312, 101531
155909	TouchFREE Ultra Soap	white & blue	8	1.2 liter	6264312, 1022312



DebMed USA
 2815 Coliseum Centre Dr #600
 Charlotte
 NC 28217
 USA
 T: 866-783-0422
 www.debmed.com

This information and all further technical advice is based upon our present knowledge and experience. However, it implies no liability or other legal responsibility on our part, including with regard to existing third party intellectual property rights, especially patent rights. In particular, no warranty, whether express or implied, or guarantee of product properties in the legal sense is intended or implied. We reserve the right to make any changes according to technological progress or further developments.

* = is a registered trademark of Deb Group Ltd. or one of its subsidiaries.
 © Deb Group Ltd 2015.